



US 20050113769A1

(19) **United States**

(12) **Patent Application Publication** (10) **Pub. No.: US 2005/0113769 A1**

Waters et al. (43) **Pub. Date: May 26, 2005**

(54) **CHEMICALLY TANNING HUMAN SKIN**

Publication Classification

(76) Inventors: **Drew Waters**, Sachse, TX (US);
Brandon Shaw, Irving, TX (US);
Frank Verdun, Franklin, TN (US)

(51) **Int. Cl.**⁷ **A61M 35/00**; G08B 13/14

(52) **U.S. Cl.** **604/289**

Correspondence Address:
Steven Thrasher
391 Sandhill Dr.
Richardson, TX 75080 (US)

(57) **ABSTRACT**

(21) Appl. No.: **10/932,438**

The invention teaches devices and methods for chemically tanning human skin. It is emphasized that this abstract is provided to comply with the rules requiring an abstract that will allow a searcher or other reader to quickly ascertain the subject matter of the technical disclosure. It is submitted with the understanding that it will not be used to interpret or limit the scope or meaning of the claims. 37 CFR 1.72(b).

(22) Filed: **Sep. 2, 2004**

Related U.S. Application Data

(63) Continuation of application No. 09/595,787, filed on Jun. 16, 2000, now Pat. No. 6,802,830.

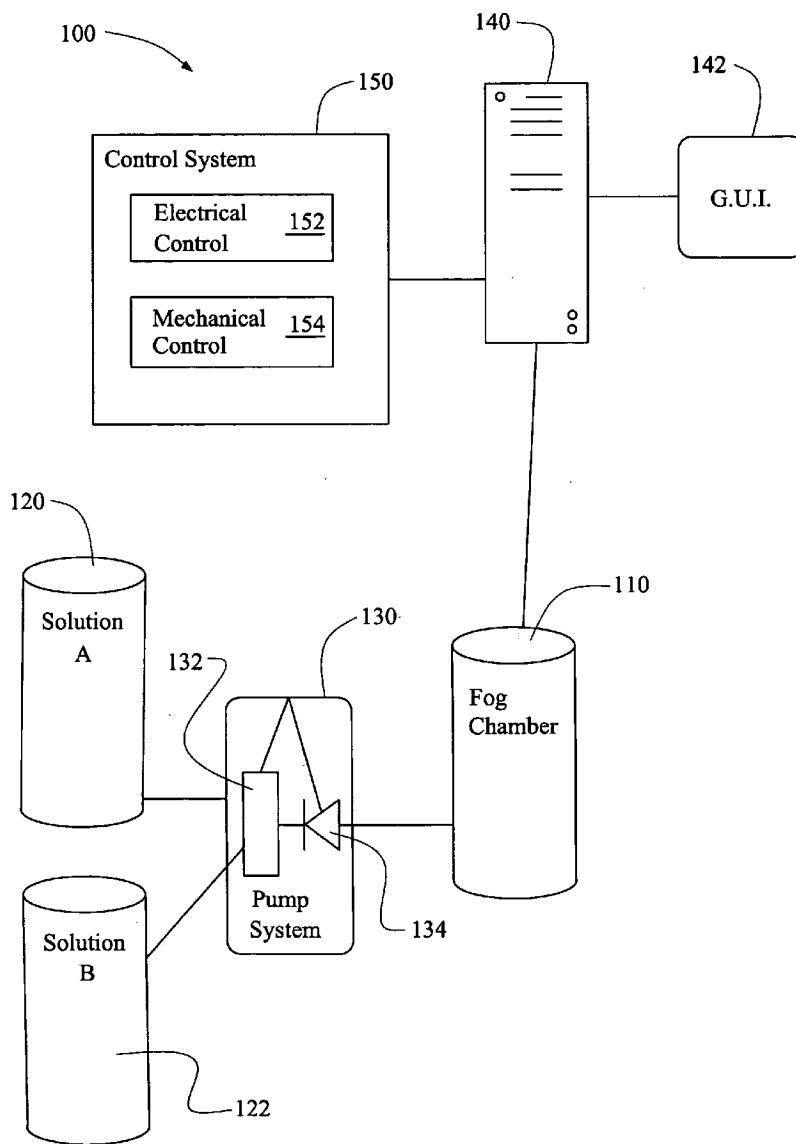

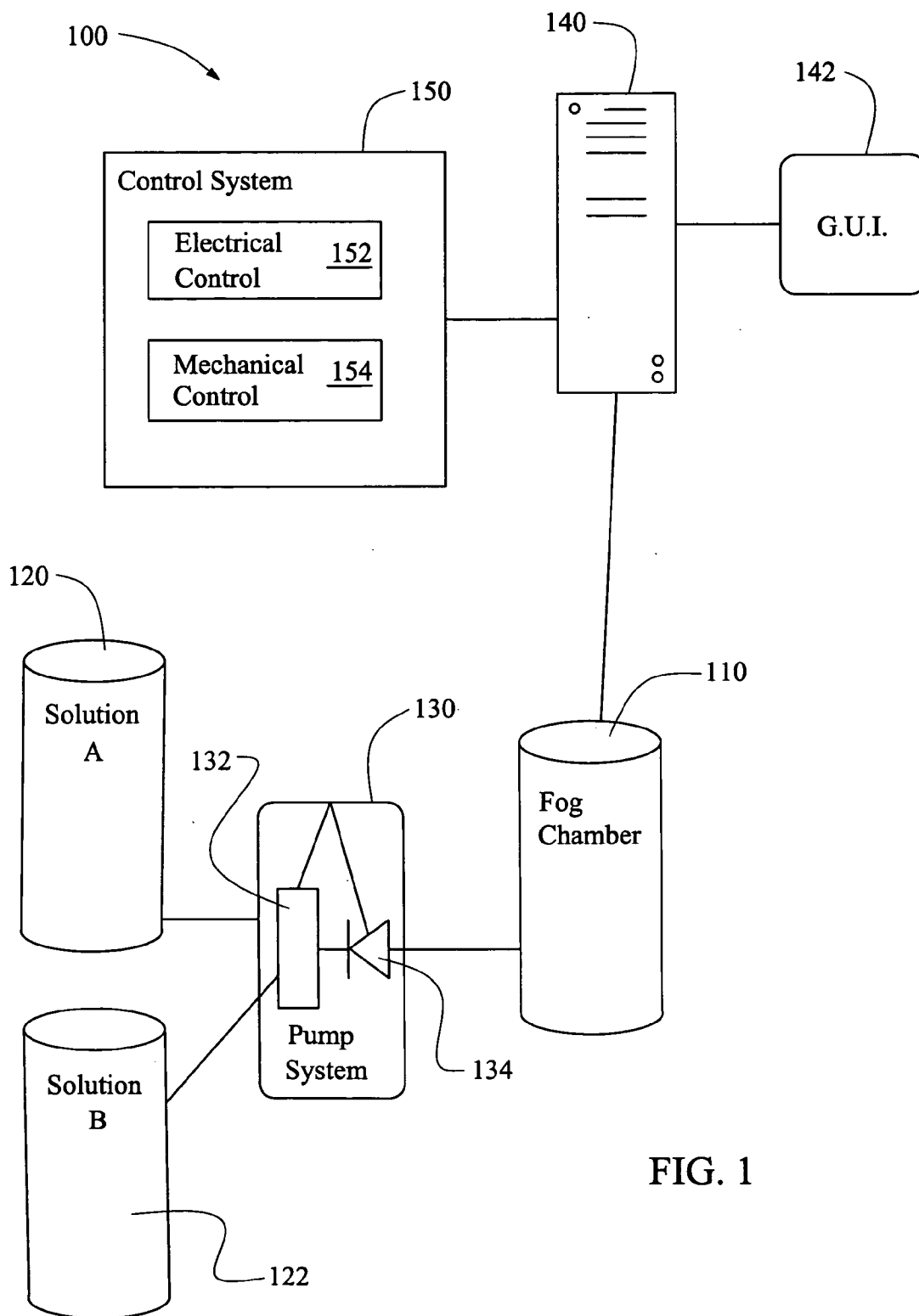
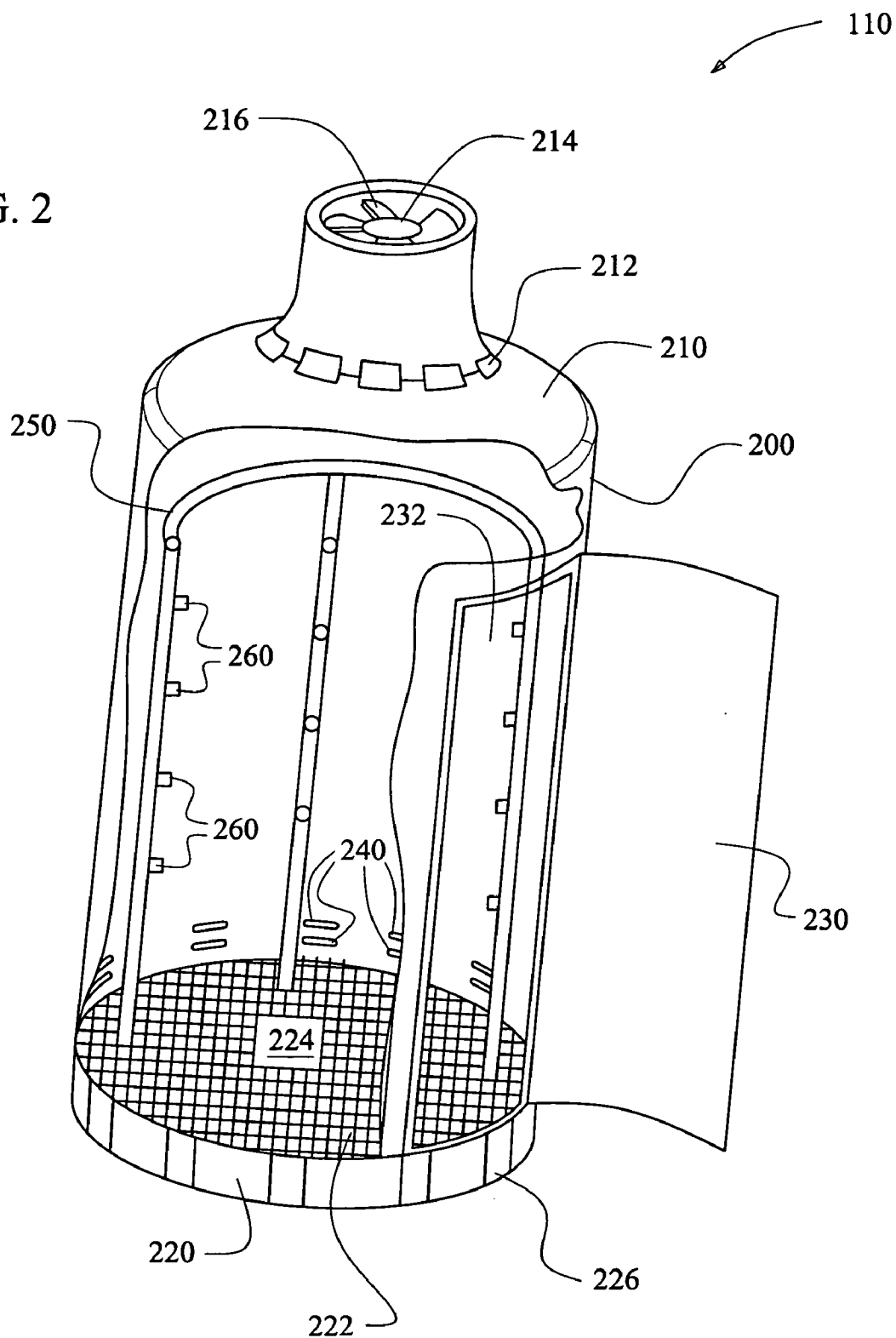

FIG. 1

FIG. 2



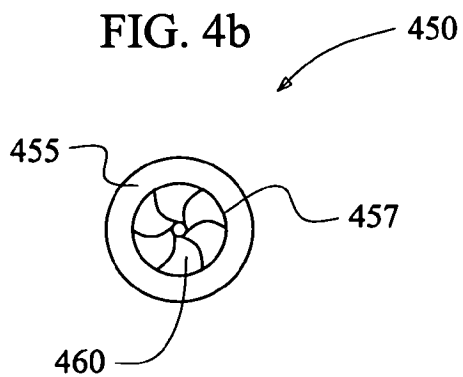
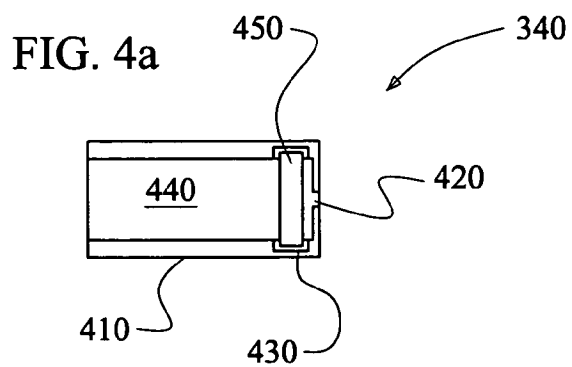
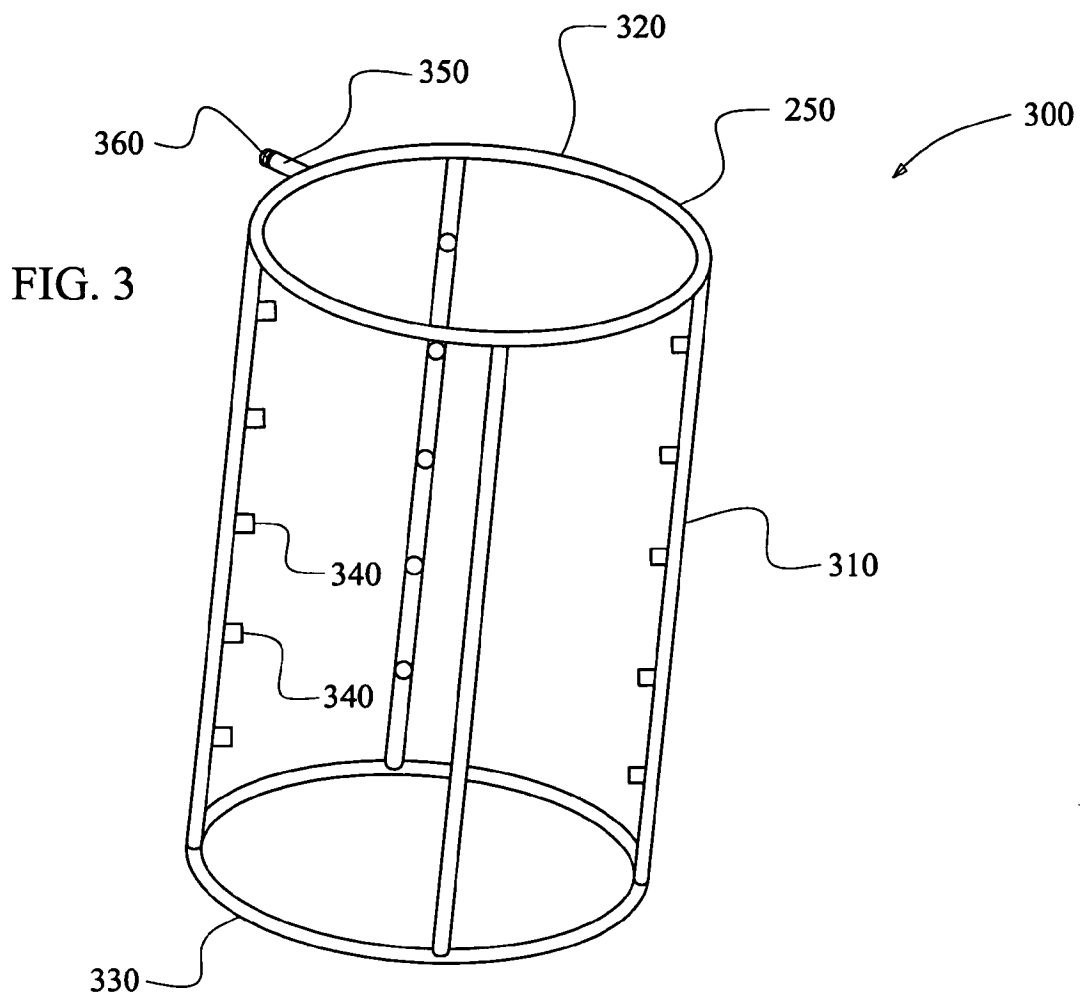
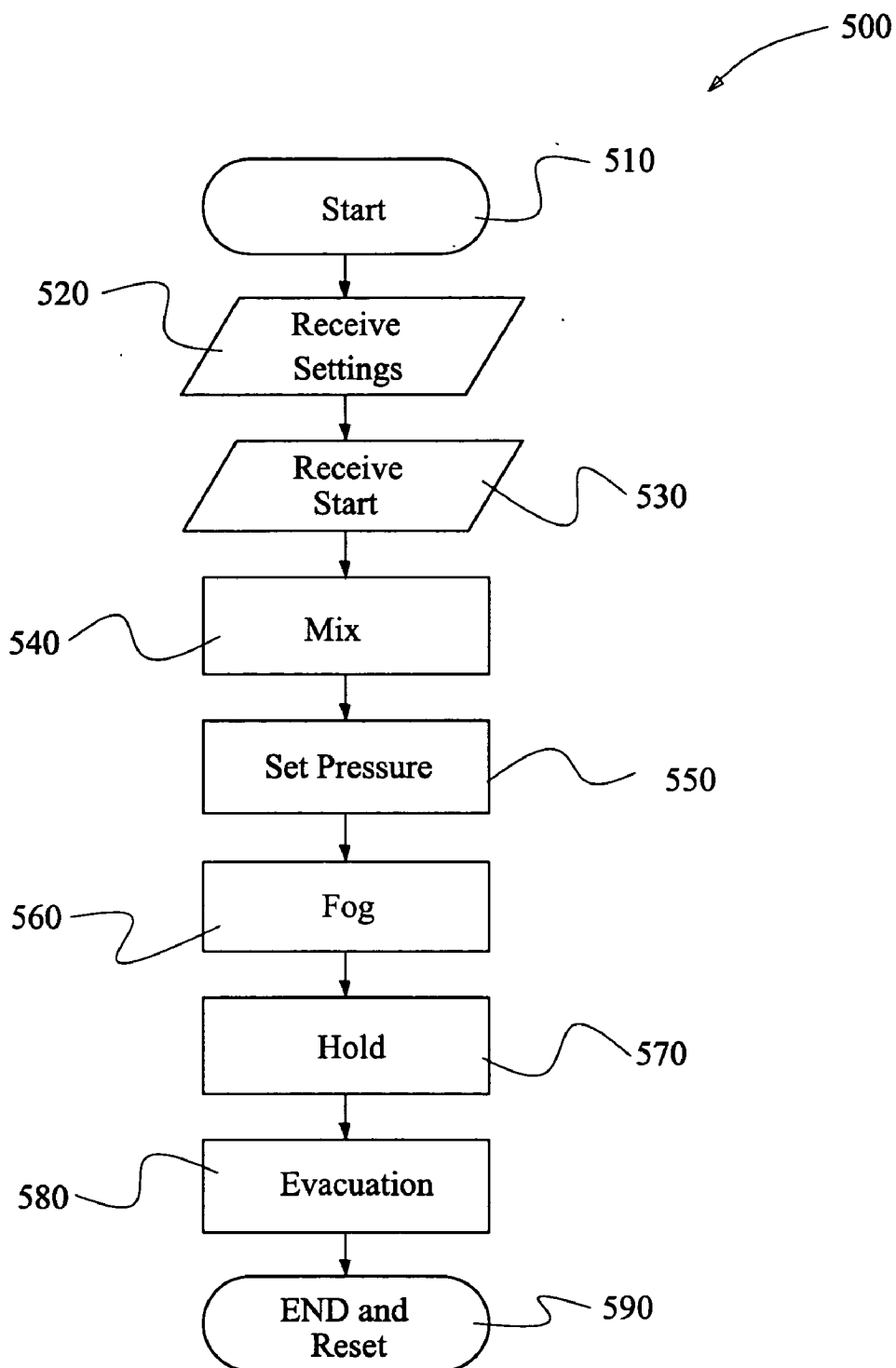

FIG. 5



CHEMICALLY TANNING HUMAN SKIN

CROSS-REFERENCE TO RELATED APPLICATION

[0001] This application is a continuation of co-pending U.S. patent application Ser. No. 09/595,787 entitled Device and Method that Generates a Fog Capable of Altering the Color of Human Skin, also by Waters, et al. filed on Jun. 16, 2000.

TECHNICAL FIELD OF THE INVENTION

[0002] The present invention relates to devices and methods for generating a fog in a closed chamber, and more particularly to devices and methods for generating a fog that is capable of altering the color of human skin.

STATEMENT OF A PROBLEM ADDRESSED BY THIS INVENTION

[0003] Interpretation Considerations

[0004] This section describes the technical field in more detail, and discusses problems encountered in the technical field. This section does not describe prior art as defined for purposes of anticipation or obviousness under 35 U.S.C. section 102 or 35 U.S.C. section 103. Thus, nothing stated in the Problem Statement is to be construed as prior art.

[0005] Discussion

[0006] For decades, a tan has been associated with good health, a nice appearance, and general well being. Health can be enhanced by tanning. For example, vitamins D and, C, and E are all generated by a person's body when that person is exposed to the sun. In fact, phrases such as "healthy glow" have entered the modern lexicon. Furthermore, many people who tan regularly report that it makes them feel rejuvenated, relaxed, and calm. Unfortunately, tanning with ultraviolet rays has drawbacks.

[0007] For example, most people associate skin cancer with ultraviolet ray exposure. Furthermore, exposure to ultraviolet rays has been associated with premature skin wrinkling, as well as cell damage which can result in dry skin and the loss of melanin. Of course, anyone who has spent a day at the beach or a lake is familiar with the fact that ultraviolet radiation exposure causes sunburns. Fortunately, devices exist that minimize exposure to ultraviolet radiation while providing a tan.

[0008] For example, since not all ultraviolet radiation is created equal, some modern tanning units use cobalt lamps to reduce a person's exposure to harmful ultraviolet (UV) radiation (beta rays), while allowing that person to be exposed to the proper UV rays to generate a tan (alpha rays). This allows a person to become darker while reducing their exposure to harmful ultraviolet radiation significantly. However, manufacturing and using these devices is prohibitively expensive.

[0009] In addition, many people use suntan lotions which have SPF ratings that indicate that the lotions block ultraviolet radiation, and thus prevent damage by ultraviolet light. Furthermore, recover products exist that provide vitamins, minerals and moisturizers to skin which has been exposed to ultraviolet radiation. Unfortunately, these products are often expensive, difficult to apply and are easily

ignored or forgotten just after exposure to UV light, which is just when they are most needed. Furthermore, none of these products provide 100 percent protection from ultraviolet radiation.

[0010] Recently, to provide a darker and more healthy looking skin complexion, it has become popular to use tanning lotions and sprays that darken skin (self-bronzing applications). For example, one device uses a carwash-like spraying apparatus to coat one side of a person at a time by either moving a spray up and down or side to side across the person. These applications have the benefit of giving a person a healthy looking tan while not requiring that person to be exposed to ultraviolet radiation. Unfortunately, these spray applicators have several disadvantages.

[0011] For example, by spraying a person one side at a time, that side that is sprayed first will have a longer exposure to the tanning spray than the side of the person which is last exposed. In addition, there is an overlap as the person turns and the sprayers hit an area more than once, resulting in a buildup of excess tanning spray at different locations on a person.

[0012] Furthermore, the use of a sprayer that sprays a person one side at a time results in a long and tedious process—a process in which the person being sprayed typically must close their eyes and hold their breather until the process is complete (which may take as long as half a minute or more). The result is that these devices are uncomfortable for a person to use, and can create uneven tanning with noticeable dark areas that can look quite strange.

[0013] However, it is desirable to provide a device which can apply a tanning solution to a person without these disadvantages. This would be particularly advantageous to persons who have been diagnosed with skin cancer and allow them to obtain a healthy looking tan without UV exposure. Therefore, there exist the need for a device and method for applying a tanning solution quickly and evenly.

BRIEF DESCRIPTION OF THE DRAWINGS

[0014] Various aspects of the invention, as well as an embodiment, are better understood by reference to the following detailed description. To better understand the invention, the detailed description should be read in conjunction with the drawings in which:

[0015] FIG. 1 illustrates some component that may be provided in one embodiment of a tanning system;

[0016] FIG. 2 illustrates one embodiment of a fog chamber;

[0017] FIG. 3 illustrates a fluid frame system for use within a generally cylindrical outer shell, such as the outer shell;

[0018] FIG. 4a illustrates a nozzle designed to produce a fog;

[0019] FIG. 4b illustrates one embodiment of the disk fan; and

[0020] FIG. 5 is a flow chart of a tanning algorithm.

EXEMPLARY EMBODIMENT OF A BEST
MODE

[0021] Interpretation Considerations

[0022] When reading this section (An Exemplary Embodiment of a Best Mode, which describes an exemplary embodiment of the best mode of the invention, hereinafter “exemplary embodiment”), one should keep in mind several points. First, the following exemplary embodiment is what the inventor believes to be the best mode for practicing the invention at the time this patent was filed. Thus, since one of ordinary skill in the art may recognize from the following exemplary embodiment that substantially equivalent structures or substantially equivalent acts may be used to achieve the same results in exactly the same way, or to achieve the same results in a not dissimilar way, the following exemplary embodiment should not be interpreted as limiting the invention to one embodiment.

[0023] Likewise, individual aspects (sometimes called species) of the invention are provided as examples, and, accordingly, one of ordinary skill in the art may recognize from a following exemplary structure (or a following exemplary act) that a substantially equivalent structure or substantially equivalent act may be used to either achieve the same results in substantially the same way, or to achieve the same results in a not dissimilar way.

[0024] Accordingly, the discussion of a species (or a specific item) invokes the genus (the class of items) to which that species belongs as well as related species in that genus. Likewise, the recitation of a genus invokes the species known in the art. Furthermore, it is recognized that as technology develops, a number of additional alternatives to achieve an aspect of the invention may arise. Such advances are hereby incorporated within their respective genus, and should be recognized as being functionally equivalent or structurally equivalent to the aspect shown or described.

[0025] Second, the only essential aspects of the invention are identified by the claims. Thus, aspects of the invention, including elements, acts, functions, and relationships (shown or described) should not be interpreted as being essential unless they are explicitly described and identified as being essential. Third, a function or an act should be interpreted as incorporating all modes of doing that function or act, unless otherwise explicitly stated (for example, one recognizes that “tacking” may be done by nailing, stapling, gluing, hot gunning, riveting, etc., and so a use of the word tacking invokes stapling, gluing, etc., and all other modes of that word and similar words, such as “attaching”).

[0026] Fourth, unless explicitly stated otherwise, conjunctive words (such as “or”, “and”, “including”, or “comprising” for example) should be interpreted in the inclusive, not the exclusive, sense. Fifth, the words “means” and “step” are provided to facilitate the reader’s understanding of the invention and do not mean “means” or “step” as defined in §112, paragraph 6 of 35 U.S.C., unless used as “means for -functioning-” or “step for -functioning-” in the Claims section. Sixth, the invention is also described in view of the Festo decisions, and, in that regard, the claims and the invention incorporate equivalents known, unknown, foreseeable, and unforeseeable. Seventh, of course, the discussions and definitions are provided for clarification purposes and are not limiting, and the language and each word used

in the invention should be given the ordinary interpretation of the language and the word, unless indicated otherwise. It should be noted in the following discussion that acts with like names are performed in like manners, unless otherwise stated.

[0027] Description of the Drawings

[0028] In one embodiment, the invention provides a tanning system. **FIG. 1** illustrates components that may be provided in one embodiment of a tanning system **100**. In the tanning system **100** a graphical user interface (GUI) **142** is provided so that an operator of tanning system **100** may select and adjust various settings of the tanning system. For example, by using the graphical user interface **142**, one may select a predetermined pressure, a predetermined program which varies pressures, a tanning solution, a combination of tanning solutions, a combination of a tanning solution and a moisturizer, or a temperature at which any of these is delivered into a fog chamber **110**. Accordingly, settings selected at the graphical user interface are supplied to a computer **140**. Alternatively, any of the settings described as being selected at the graphical user interface **142** may be selected by a user within the fog chamber **110** via a control pane (not shown).

[0029] The computer **140** may be any comprising platform capable of executing a computer code, which enables the tanning system **100**. For example, the computer **140** could be a personal computer (PC), a laptop, or a specific use-computing device. Preferably, the computer **140** stores and executes a tanning system algorithm (discussed later).

[0030] The computer **140** is coupled to a control system **150**. The control system **150** typically houses an electrical control subsystem **152**, and a mechanical control subsystem **154**. The control system **150** opens and closes valves within a pump system **130** so as to implement the settings directed at the graphical user interface **142**, or by a user at the control panel. Accordingly, the electrical control subsystem **152** is generally controlled by the computer **140** so as to actuate the mechanical control subsystem **154**.

[0031] The mechanical subsystem **154** implements the opening and closing of valves within the pump system **130**, such as the flow valve **134**, and the valve(s) in the pump **132** which controls the flow of solutions into the pump system **130**. It should be noted that although the control system **150** appears in **FIG. 1** to be rather larger, the control system **150** is typically a quite small device.

[0032] The control system **150** is thus coupled to the pump system **130** so as to control the valves therein. Furthermore, the pump system **130** accepts solution from a first solution container **120**, containing a Solution A, and a second solution **122** containing a Solution B. The Solution A and the Solution B may be tanning solutions or moisturizers or other solutions or liquids to be delivered to the fog chamber **110**. The pump **132** places the incoming solutions under pressure, and preferably places the solutions at predetermined pressure.

[0033] For example, if a liquid with water-like consistency is pumped, then the predetermined pressure may be between 450 and 550 psi, and is preferably 500 psi. Similarly, if a lotion is pumped, the predetermined pressure may be between 550 and 650 psi, with a preferred predetermined pressure of 600 psi. Likewise, the flow valve **134** is opened

and closed by the control system **150** so as to allow the tanning solution which exits the pump **132** at the predetermined pressure to pass into the fog chamber **110**.

[0034] A fog chamber **110** is a generally enclosed housing used to encapsulate a fog about a person being tanned, and to maintain the fog at a predetermined density. **FIG. 2** illustrates one embodiment of a fog chamber **110**. The fog chamber **110** is generally comprised of an outer shell **200**, a hood **210** and a floor **220**. The hood **210** is preferably a plastic of fiberglass form capable of supporting a lighting system **212** as well as a fan motor **214**. The fan motor **214** drives fan blades **216** to vent and evacuate the chamber.

[0035] Accordingly, during operation, the lighting system **212** provides lighting within the fog chamber **110**. In addition, the fan motor **214** operates at a low speed during the fogging process to provide ventilation within the fog chamber **110**, and at high speed to quickly evacuate the fog chamber **200** when the person being tanned has been exposed to the fog for a sufficient time.

[0036] The floor **220** includes a plurality of legs **226**, which support a generally mesh-like floor piece **222** thereon. The floor piece **222** is elevated above the floor **220** in order to provide ventilation about the feet of the person being tanned. Furthermore, the floor piece **222** includes a standing platform **224** on which a person may stand without their feet being irritated by the floor piece **222**. In addition, the generally mesh nature of the floor piece **222** allows condensation and excess fog to fall to the floor **220**.

[0037] The outer shell **200** provides a door **230**, which opens and shuts about a doorway **232** for providing access into the tanning chamber **110**. The outer shell **200** like the hood **210** is preferably made of a fiberglass or a moldable plastic. Also provided within the outer shell **200** are a plurality of vents **240** for providing fresh air access into the fog chamber **110**. Disposed within the outer shell **200** is a fluid frame **250**, which provides tanning solution (or other liquid or lotion) to the fog chamber **110**. The fluid frame is preferably constructed of $\frac{3}{8}$ " copper pipe and contains a plurality of nozzles **260** thereon.

[0038] Each fluid frame is customized to provide a generally uniform fog to a user within the fog chamber **110**. Accordingly, the fluid frame, in operation, is generally disposed about the person being tanned. **FIG. 3** illustrates a fluid frame **300** for use within a generally circular top frame piece **320**, a generally circular bottom frame **330**, and a plurality of vertical frame pieces **310**. Each of the frame pieces **310**, **320**, **330**, may be fluidly connected to a plurality of nozzles **340**.

[0039] The number and location of the nozzles **340** is chosen based on the desire to produce a generally uniform fog within the area generally enclosed by the fluid frame **250**. Furthermore, each nozzle **340** is pointed in a direction that supports the creation of a uniform fog within the fog chamber **110**. Also coupled to the fluid frame **250** is an empty pipe **350**, which brings the tanning solution (or tanning solution mixture) into the fluid frame **250**. Controlling access of a fluid to the fluid frame **250** via the entry pipe **350** is an entry valve **360**.

[0040] The entry valve **360** provides a user of the tanning system the ability to quickly turn the tanning system off should that user desire to do so. Accordingly, the entry valve

360 is typically coupled to the computer **140**, or the control system **150**. Alternatively, the entry valve **360** maybe directly mechanically turned on and off by an off switch (not shown) within the fog chamber.

[0041] A nozzle capable of producing a fog is utilized by the invention. Accordingly, **FIG. 4a** illustrates a nozzle **340** designed to produce a fog. The nozzle **340** includes a generally cylindrical shell **410** having an orifice **420** at one end (the end the fog exits, the other end being attachable to the fluid frame) and maintaining a cylinder **440** therein. The orifice **420** is of a size, which enables the nozzle **340** to produce a fog, and is preferably between 0.005 and 0.0200 inches in diameter, and is preferably 0.012 inches in diameter. Furthermore, the nozzle **340** provides an annular indentation **430** capable of supporting a disk fan **450** therein.

[0042] **FIG. 4b** illustrates one embodiment of the disk fan **450**. The disk fan **450** provides a generally circular outer ring **455**, which supports a plurality of fan blades **460** within its inner radius **457**. Referring to **FIGS. 4a** and **4b**, when a fluid is passed in the chamber **440**, and through the orifice **420**, the flow of the fluid causes the fan blades **460** to turn the disk fan **450** so that the disk fan **450** rotates rapidly. The rapid spinning of the disk fan **450** causes a more even and uniform dispersion of a fog within the fog chamber **110**. This provides the additional advantage of preventing a user of the tanning system from being irritated by a direct spray.

[0043] Exemplary Method

[0044] One embodiment of a method according to the invention may be understood as a tanning algorithm **500**. **FIG. 5** is a flow chart of a tanning algorithm **500**. First, in a start act **510**, the tanning system algorithm **500** is loaded into a computer memory and performs all of the procedures needed to initialize a control system or a pump system and may heat any fluids to a predetermined temperature. Then, in a receive settings act **520**, the settings selected at either the graphical user interface or a user control panel within the fog chamber are received by the tanning system algorithm **500**.

[0045] The settings may include a selection of a temperature for a tanning solution, a predetermined fogging program which implements variable fog densities for predetermined times, a selected time period for exposure to a fog, a selected fog density, or settings. Next, in a receive start act **530**, the tanning system algorithm **500** receives an indication that the fogging process is to begin. The receive start act **530** may be initiated by a user within the fog chamber, by a person at a graphical user interface, or automatically via computer program.

[0046] The tanning system algorithm **500** next proceeds to a mix act **540** in which any tanning solution mixtures selected are either mixed prior to being placed in a pump, or either set so that they may be mixed by a pump. Then, in a set pressure act **550**, the tanning solution (or tanning solution mixture, but collectively "tanning solution") is pumped to a user-selected pressure. Next, the fog act **560** is implemented by the opening of valves, which allow the tanning solution to flow into a fog chamber. Also within the fog act **560** a fog is produced within the fog chamber **110**. In a hold act **570** the fog density is controlled and held at a predetermined density, which is either user, selected or selected by a program, which was selected by the user or the person operating a graphical user interface. Preferably, during the

hold act 570, a fan is operating at a low speed in order to vent air into the chamber at a predetermined rate.

[0047] The fog evacuated from the fog chamber 110 in an evacuation act 580. Preferably, the evacuation act 580 is very fast, and preferably almost instantaneous. Then, the tanning system algorithm 500 continues to end and reset act 590. The end and reset act 590 terminates the execution of the tanning system algorithm 500 and resets the pre-pump system and the control system so that another user may enter and use the fog chamber 110.

[0048] Sometimes methods of the invention may be practiced by placing the invention on a computer-readable medium. Computer-readable mediums include passive data storage, such as a random access memory (RAM) as well as semi-permanent data storage such as a compact disk read only memory (CD-ROM). In addition, the invention may be embodied in the RAM of a computer and effectively transform a standard computer into a new specific computing machine, such as a tanning system.

[0049] Of course, it should be understood that the order of the acts of the algorithms discussed herein may be accomplished in different order depending on the preferences of those skilled in the art, and such acts may be accomplished as software. Furthermore, though the invention has been described with respect to a specific preferred embodiment, many variations and modifications will become apparent to those skilled in the art upon reading the present application. It is therefore the intention that the appended claims and their equivalents be interpreted as broadly as possible in view of the prior art to include all such variations and modifications.

We claim:

- 1. A method of generating a mist with a tanning solution, comprising:
 - applying a predetermined pressure to a tanning solution; and
 - passing the tanning solution through a first stationary tube,
 - the first stationary tube maintained in a chamber, and
 - the first stationary tube having a first nozzle in the chamber such that as the solution leaves the first nozzle a mist is generated in the chamber.
- 2. The method of claim 1 further comprising passing the tanning solution through a second stationary tube,
 - the second stationary tube maintained in the chamber, and
 - the second stationary tube having a second nozzle in the chamber such that as the solution leaves the second nozzle a mist is generated in the chamber, the mist from the second nozzle being substantially directed into the mist from the first nozzle.
- 3. The method of claim 1 wherein the nozzle is stationary with respect to the tube.
- 4. The method of claim 1 wherein the chamber is sufficiently large to hold an entire person therein.
- 5. A method of generating a fog with a tanning solution, comprising:
 - applying a predetermined pressure to a tanning solution; and

- passing the tanning solution through a first stationary tube,
 - the first stationary tube maintained in a chamber, and
 - the first stationary tube having a first nozzle in the chamber such that as the solution leaves the first nozzle a fog is generated in the chamber.
- 6. The method of claim 5 further comprising passing the tanning solution through a second stationary tube,
 - the second stationary tube maintained in the chamber, and
 - the second stationary tube having a second nozzle in the chamber such that as the solution leaves the second nozzle a mist is generated in the chamber, the fog from the second nozzle being substantially directed into the fog from the first nozzle.
- 7. The method of claim 6 wherein the nozzle is stationary with respect to the tube.
- 8. The method of claim 7 wherein the chamber is sufficiently large to hold an entire person therein.
- 9. A method of generating a fog with a tanning solution, comprising:
 - applying a predetermined pressure to a tanning solution;
 - passing the tanning solution through at least two tubes, each tube having at least a nozzle in a chamber sufficiently large to hold an entire person therein, such that as the solution leaves the nozzle a fog is generated in the chamber;
 - holding the fog in the chamber for a predetermined time; and
 - evacuating the fog from the chamber.
- 10. The method of claim 9 wherein the tanning solution is a combination of a first tanning solution and a second tanning solution.
- 11. The method of claim 9 wherein the tanning solution is a combination of a tanning solution and a moisturizer.
- 12. The method of claim 9 further comprising the act of selecting a combination of at least one tanning solution and at least one moisturizing solution.
- 13. A tanning system, comprising:
 - a chamber having at least two tubes, each tube maintaining tanning solution and each tube having at least a stationary nozzle disposed in the chamber;
 - a pump system in fluid communication with each tube in the chamber;
 - a first tanning solution container coupled to the pump system;
 - a moisturizer solution container coupled to the pump system; and
 - a control system coupled to the pump system.
- 14. A system that generates a fog with a tanning solution, comprising:
 - an outer shell;
 - a stationary fluid frame disposed within the outer shell; and

at least one stationary nozzle in the fog chamber, and in fluid communication with the fluid frame, the stationary nozzle capable of turning a tanning fluid into a fog by passing the fluid through an orifice.

15. The fog chamber of claim 14 further comprising a user control panel disposed within the outer shell, the user control panel, the control panel providing a user the ability to select a tanning solution from a plurality of tanning solution choices.

16. A tanning system that generates a fog with a tanning solution, comprising:

a fog chamber;

a pump system in fluid communication with the fog chamber;

a control system coupled to the pump system; and

a computer coupled to the control system.

17. A tanning system that generates a fog with a tanning solution, comprising:

a fog chamber;

a pump system in fluid communication with the fog chamber; and

a control system coupled to the pump system; wherein the control system comprises an electrical subsystem and a mechanical control subsystem.

* * * * *